

TRANSPORT OF COILED MATERIALS IN CONTAINERS

StopLoss 13 - 2016

StopLoss series

StopLoss briefings are developed on a broad range of topics that give rise to recurring problems. They seek to provide a straightforward summary of an issue, essential good practice advice and, where applicable, sources of further information.

The complete series and further information is visible at www.ttclub.com/lossprevention and printed copies are available from the TT Club's Regional Centres.

Acknowledgements

The information contained in this StopLoss briefing has been formulated from the TT Club's insurance experience. However, the Club gratefully acknowledges the advice and support in the preparation of this guidance of the CINS Organisation and Bill Brassington, ETS Consulting.

The information in this briefing has been prepared for information purposes only and must be considered in the context of any specific operational situation. Whilst every care has been taken to ensure the accuracy of the guidance, the contributors and the TT Club accept no responsibility for loss or damage which may arise from reliance on information contained herein.

1. INTRODUCTION

Coiled materials can be safely carried in containers, so long as they are properly packaged, packed and secured. The guidance in this document is applicable to coiled materials of all dimensions and materials, but is specifically aligned to metallic products such as:

- Sheet steel, galvanised and stainless
- Slit steel, galvanised and/or stainless
- Coiled wire rod
- Aluminium sheet
- Tin sheet

Coiled materials tend to have a very high mass and, being circular, have a significantly smaller loading 'footprint' or point loading than a case of similar weight. Coiled materials exceeding weight and stress limits in General Purpose (GP) containers should be carried by other means.

Specific issues to be considered include:

- Cold roll steel, materials with treated surfaces and aluminium should be protected from scratching and environmental conditions which may cause corrosion
- Coils need to be properly secured to prevent the coil from telescoping
- Coils need to be packed so that the coil is not damaged due to undue pressure, causing the coil to flatten (ovalise)

It is intended to conform with the IMO/ILO/UNECE Code of Practice for Packing Cargo Transport Units (CTU Code) and provide supplementary information to assist in the safe transport of these materials by any mode.

This guidance generally addresses the use of GP containers. Specialist packing advice should be sought from the container/CTU operator. This document considers risk prevention through correct:

- Packing arrangements
- Securing
- Protection

1. INTRODUCTION (CONTINUED)

1.1 Forces

Maritime transport is subject to a variety of forces that are depicted in the following illustration:

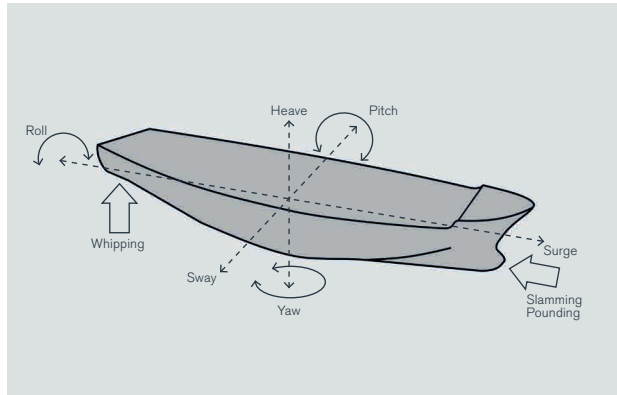

Diagram 1

Longitudinal and transverse forces acting on the coils during road, rail and sea transport are demonstrated in Diagram 2:

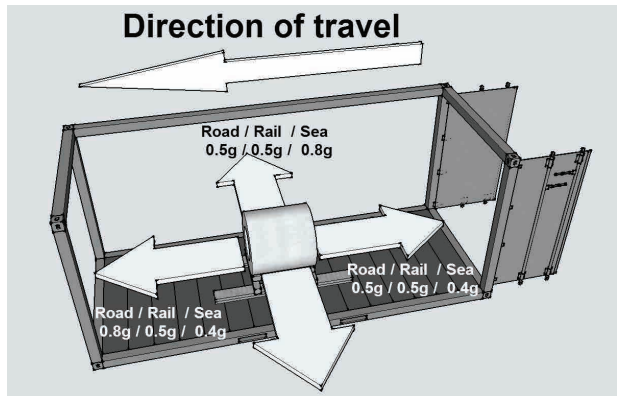

Diagram 2

Diagram 2 shows a coil orientated 'Eye to Rear' (see also Diagram 3 opposite). Coils orientated like this have an increased risk of moving transversal inside the container during maritime transport. During road transport the longitudinal force acting on a coil orientated 'Eye to Side' presents the greatest risk especially to the driver of the vehicle.

1.2 Packing arrangements

Three different types of packing arrangements are available for the coil transport. The orientation of the coil depends on:

- Available handling equipment
- Overall dimensions (diameter and/or height) and
- Mass (dictating whether the available container is suitable on the basis of distribution and floor strength)

The coil orientation uses the direction of the coils axis and refers to this as the “EYE”.

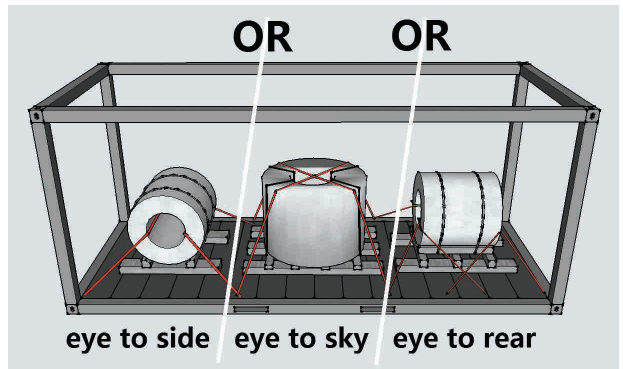

Diagram 3

2. GENERAL PRINCIPLES

Safe practice. The packing of coiled materials is a systematic process, requiring consideration of load distribution, packing, blocking/bracing and lashing.

For more information chapters 4 and 8 of the CTU Code should be consulted.

There are some basic rules that have to be followed:

- **The maximum gross mass** (cargo + bedding and securing ('payload') + tare mass of the unit) **of the container should not be exceeded**
- The cargo mass should be distributed over sufficient length of the container floor
- Coils should not rest directly on the container floor
- Cradles (also known as 'wedge beds') may be used to support and retain the coils
- Coils should be adequately secured to the cradle or support arrangements
- Ensure coils are secured adequately and cannot move inside the container
- Blocking/bracing should be used to secure the coil and may be used in combination with lashing gear attached to the anchor points situated on the base structure of the container

2.1 Container structural integrity

The **Packer** should ensure that the container is thoroughly checked before packing and be satisfied that the condition of the container is suitable for the cargo to be transported. Containers should:

- Be fit for purpose
- Comply with international structural integrity requirements
- Comply with international or national safety regulations and
- Be clean, free from cargo residues, noxious materials, plants, plant products and visible pests

The **Packer** should also ensure the following:

- A safety approval plate (CSC plate) has an ACEP mark or a Next Examination Date (NED). The NED should fall after the expected arrival time of the container at its destination
- The structural framework is in good condition
- The doors of the container work properly
- Labels, placards, marks or signs regarding previous usages of the container have been removed and
- Before entering a closed container, the doors are opened for at least ten minutes to allow the internal atmosphere to regularise with the ambient

2.2 Load distribution

It is essential that the packed container's centre of gravity is kept as close as possible to the longitudinal and transverse centre lines.

- A **single** coil should be placed in the middle of the container, longitudinal and transverse
- **Two coils of equal mass** should be positioned in longitudinal direction as wide as possible out from the middle, one to the rear end and the other to the front end of the container
- **Multiple coils** should be positioned to ensure that the load distribution of the container is evenly distributed and not off-centre

It is also essential that the mass of the coil is distributed by the use of timber or steel bedding beams. The length of such beams is dependent on its cross section, the mass of the coil and their free ends. Timber beams should be of appropriate quality (see next page).

Bedding beams should be laid in a longitudinal direction to distribute the coils mass over a number of cross members.

Be aware that, where the section of the bedding beams is insufficient, the mass of the coil may cause deflection of the beams, compromising the intended support.

As a general guideline, the standard ISO container (both wooden and metal floors) has a weight limit of 4,500kg per running metre in length direction, when the bedding is laid as far from the centre as possible and at least a distance of 100cm between each beam. Less width reduces the weight bearing limit - greater width increases such limit. Therefore the bedding should always be placed as far as possible out from the centre line, close to the side walls. Some containers are available with stronger floors. Consult your container operator for detailed weight limits.

When coils are positioned into the container using a forklift, it is important that the force exerted by the laden forklift do not overstress flooring and cross members. For further information, refer to the CTU Code.

2. GENERAL PRINCIPLES (CONTINUED)

2.2.1 Cradle or support arrangements

Coiled materials may be presented for packing in different ways, from basic skeletal support arrangements through to cradle structures.

Cradles can be constructed to provide additional support, particularly for use with larger steel coils (see as an example Diagram 4). In general these cradles would be as wide as the container.

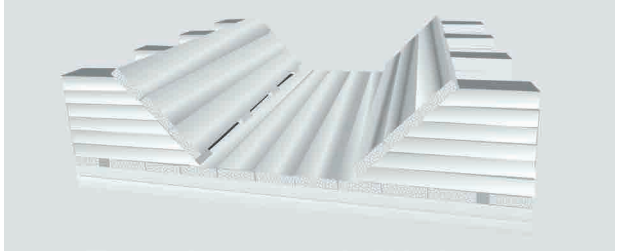

Diagram 4

However a coil is presented, it is important to consider how best to support and restrain it corresponding to its mass and orientation in the container.

2.2.2 Quality of wood

The quality of timber to be used for blocking, bracing and bedding beams is critical and should be appropriate for the density of cargo being packed. Purchase a known grade from a trusted supplier and consider the following factors:

- Durability – the timber should be able to withstand the longitudinal and compressive forces that are exerted on it. Avoid timber with multiple knots
- Moisture content – timber with high moisture content will compress and shrink, compromising its performance. Properly dried timber should always be used
- Treatment – timber used for packing purposes should comply with any phytosanitary requirements (such as ISPM 15) to prevent the transport of invasive alien species

2.3 Packing and securing

Coiled materials should be secured on some form of structure and should not be placed directly on to the floor of the container.

- Eye to sky may be secured to pallets which may incorporate bedding beams
- Eye to rear may be secured to longitudinal bedding beams
- Eye to side may be secured on a cradle and placed on longitudinal bedding beams

Packing methods described in this document refer to solutions that can be constructed within the packer's facility. Alternative proprietary prefabricated cradles /cassettes (constructed in steel, styrofoam or other materials) may be used. Where this is done, packers should follow the manufacturer's instructions for effecting packing and securing.

The packing and securing process follows a number of stages:

2.3.1 Bedding beam

Pairs of bedding beams should be placed in a longitudinal direction on the container floor.

The required length can be calculated with the line load of the container floor. Bedding beams do not need to extend to the ends of the container. It is important that they are the right length and the cradle or support arrangements are braced against the container structure. Bracing of bedding construction should be extended to the side walls of the container, planned according to the mass and dimensions of the coils.

Bedding beams transfer the cargo mass through the container floor to a greater number of cross members, thus permitting a greater mass to be carried. The cradle or support arrangements should be secured centrally on the bedding beams. The length that protrudes from each end is referred to as the 'free end'. The value of the free ends depends on the size of timber used. It can be calculated as following:

$$\text{free end (cm)} = \sqrt[3]{\frac{\text{width(cm)}+\text{height(cm)}^2}{0.008}}$$

Example:

- Free ends of timber 10x10cm is maximum 50cm
- Free ends of timber 15x15cm is maximum 75cm
- Free ends of timber 20x20cm is maximum 100cm

2. GENERAL PRINCIPLES (CONTINUED)

It is necessary to find out the length of the cradle of the coil which is resting on the floor. Take the difference to the required bedding length, divided by 2 and you get the distance of the free end of your cargo. With above formula you can choose a timber size needed.

Example: A 7,600kg steel coil placed with eye to rear, with bedding set at least 100cm apart, requires a bedding length of $7,600\text{kg} / 4,500\text{kg/m} = 1.69\text{m}$ long bedding. Assuming this coil is on a 90cm long cradle, the free end of the bedding is $(169\text{cm} - 90\text{cm}) / 2 = 40\text{cm}$. Therefore two timbers with a size of 170x8x8cm would be sufficient.

The bedding of one coil should not overlap with the bedding of the next coil.

2.3.2 Blocking/bracing

Low-level blocking is to prevent that coils are sliding in longitudinal or transverse direction. High level blocking will prevent the coil from tipping. Blocking against the door should not be used since it presents a serious risk to operators when opening the unit. The blocking should be installed to the front end inside the small recess of the corner post. Blocking installed to the side wall or rear end must be set horizontal and needs to touch as many as possible of the corrugations.

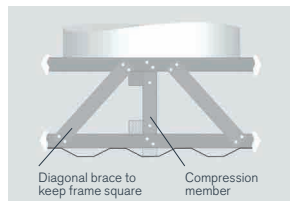

Diagram 5



Diagram 6

- The image above illustrates the use of horizontal bracing beams against the side walls. Compression blocking beams ensure rigidity of the blocking
- The beams should extend the entire length of the container along the side wall
- To prevent longitudinal movement block the cargo against the end wall and front wall door recess

Safe Practice. Containers have limited lashing capabilities and lashing of the cradle within a container should under no circumstances be considered sufficient as a standalone solution to secure coiled materials. Blocking and bracing is required in all cases.

2.3.3 Lashing

- a. The coil should be secured to the cradle/bedding with steel strapping lashing to ensure that it stays in place.
- b. Once the coil is secured to the cradle/bedding, and the cradle/bedding is blocked and braced, then adequate lashing should be applied.

Lashing of sufficient strength may for example be single use lashing belts, wires or chains, properly fixed and approved for container transport. It is necessary to apply more lashing where coils are packed 'Eye to Rear' (typically double the number).

Only the lashing rings on the floor sides and recesses should be used for securing the cradle. Only apply a maximum of one lashing per lashing ring. Don't use the lashing rings along the top side rail.

2.3.4 Door end bracing

When blocking towards the door end, use a bulkhead of adequate dimensions and strength fitted into the recess and block against that. Ensure that the doors are free from any contact with the bulkhead structure. Wherever possible fit the bracing battens at the side of the container. Angled braces (shown as broken lines in Diagram 8) may be used.

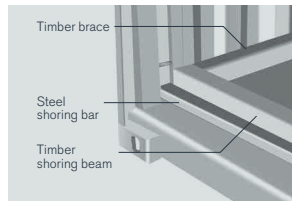

Diagram 7
Use recess

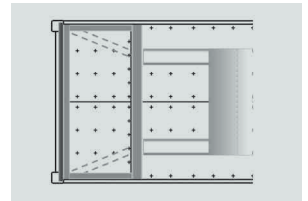
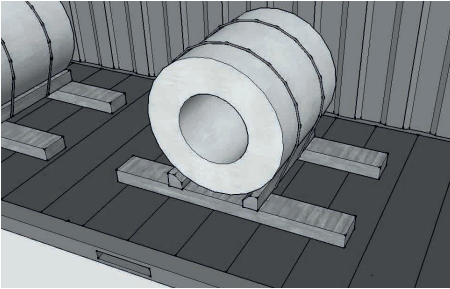

Diagram 8
Blocking at door end

3. PROCESS DIAGRAMS BY ORIENTATION

3.1 Eye to side



3.1.1 Bedding beams

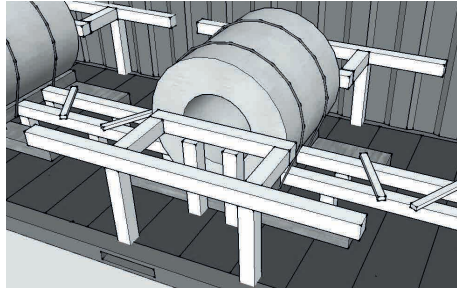

3.1.2 Blocking/bracing

3.2 Eye to rear

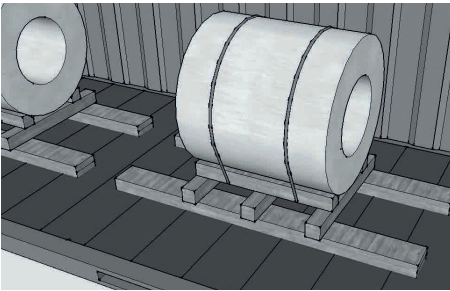

3.2.1 Bedding beams

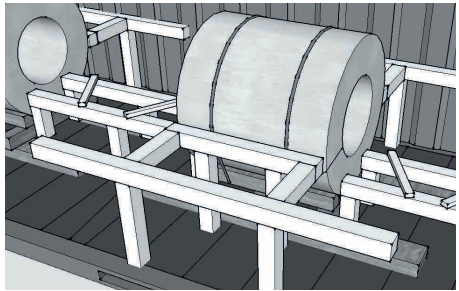

3.2.2 Blocking/bracing

3.3 Eye to sky

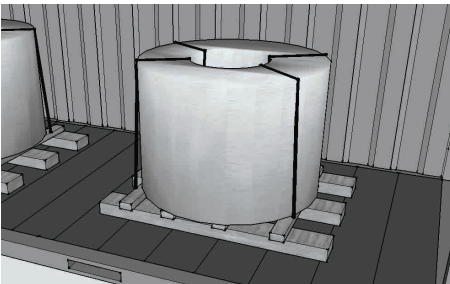

3.3.1 Bedding beams

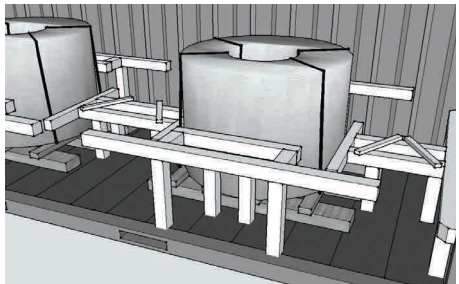

3.3.2 Blocking/bracing

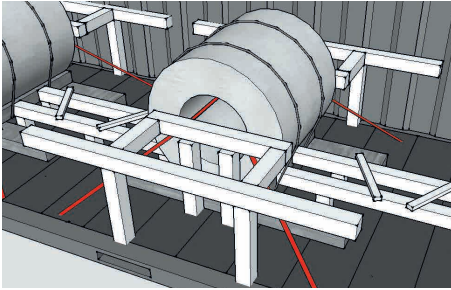

3.1.3 Lashing

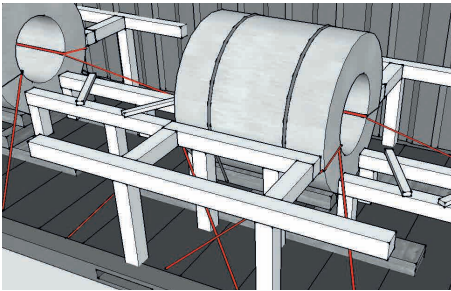

3.2.3 Lashing

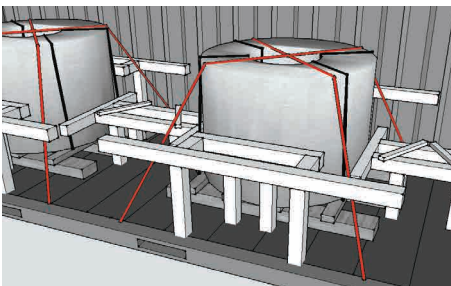

3.3.3 Lashing

4. GENERAL CONSIDERATIONS

Those intending to consign coiled materials additionally need to consider a number of other factors apart from ensuring that the cargo is appropriately packed. This section of the guidance provides some general comments; more detailed risk assessment and mitigation information will depend on the precise nature of the materials.

3.1 Material protection

The degree of protection required differs in accordance with the type of coiled material being carried. Softer materials need protection from uneven surfaces and securing materials. Absorbent materials and steel coils need protection from moisture. Coiled materials generally need protection from impact damage and, for those materials that are unreeled automatically, edges need to be protected and kept straight.

3.1.1 Wrapping

The diagram shows typical components that may be used for coiled materials, although not all will necessarily be protected (e.g. hot rolled steel). However, steel and other metallic materials may be encased in an outer wrapping of one or more layers of kraft paper, plastic sheet or thin sheet steel. This outer wrapping should be held in place by wide straps and banding. End coverings, using the same materials as the wrapping should then held in place using inner and outer edge protectors, often hard plastic or formed fibre board. The edge protectors will also prevent damage to the coiled material.

Flat metal bands are generally passed transversely through the core piece of each unit and additional bands around the circumference to secure the packing in place. The banding is also applied to ensure that the coil remains tightly wound.

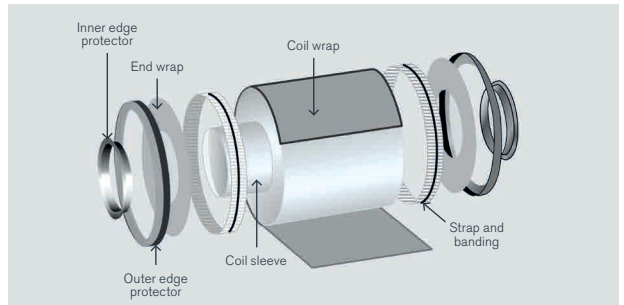

Coil wrapping layers

3.1.2 General handling damage

Coiled materials are susceptible to damage through the processes of packing and unpacking. Where the coils are impacted, physical damage may result to the plate edges. The significance of such damage depends on the intended purpose for the material. For example, buckling or bending of metal plate edges may be of importance when the affected plating is actually turned over to form a fold or bent beyond the elasticity of the material.

Care needs to be taken in the coiling process to ensure that edges of the material are in line. If the edges are allowed to project, the coiled material is prone to telescoping, especially at the centre core turns. Damage to the coils during handling and once packed may result, which is unrelated to transport activity. Poor lashing and/or securing may also result in this type of damage.

4. GENERAL CONSIDERATIONS (CONTINUED)

3.1.3 Handling at the destination

It should be remembered that coils need to be lifted into a container generally using specialised equipment. Shippers should ensure that there are suitable facilities and equipment at the point of unpacking to ensure that the cargo is not damaged by the use of inadequate handling equipment.

3.2 Climatic considerations

Climatic conditions (temperature and humidity) affect the various types of coiled material in different ways. Corrosion and oxidation affects metal products, while condensation can have a negative effect on all materials. It is necessary to take account of the anticipated routing through the entire journey from the point of origin through to destination in order to apply appropriate mitigation, such as anti-humidity materials.

While the use of containers to carry coiled materials may reduce exposure to certain atmospheric risks, it is important to ensure that the unit is sound, clean and dry prior to commencing packing. Furthermore, the coiled materials themselves should be dry and other materials that may be sources of moisture, such as wet dunnage, should not be used. Damage can arise through contact with rain during packing and/or unpacking from the container.

3.3 Contractual risk factors and loss prevention

In containerised shipments, the carrier in reality has no opportunity to check the condition of cargo packed in a general purpose container.

However, if the carrier is or should be aware that the coiled materials show excessive deterioration, such as rust, at the commencement of transport, the freight documents may be claused accordingly or the cargo rejected for shipment.

3.4 Other important factors to remember

- Regulations may require drivers of road vehicles to 'certify' that coiled materials are properly secured
- Special conditions, including indemnity provisions, may be applied for carriage by rail of coiled materials in containers
- Coiled material shipments must be clearly identified in shipping documents
- A diagram of the blocking/bracing arrangements should be attached to the documents
- Coiled material shipments are often subjected to inspection on arrival in the receiving country
- Use of special prefabricated coil transport cassettes may be preferable
- Packaging and shipping instructions must be very clear
- Always pay attention to detail



TT Club is the international transport and logistics industry's leading provider of insurance and related risk management services. Established in 1968, the Club's membership comprises ship operators, ports and terminals, road, rail and airfreight operators, logistics companies and container lessors. As a mutual insurer, the Club exists to provide its policyholders with benefits, which include specialist underwriting expertise, a world-wide office network providing claims management services, and first class risk management and loss prevention advice.

THOMAS MILLER

Thomas Miller is an independent and international provider of insurance, professional and investment services. Founded in 1885, Thomas Miller's origins are in the provision of management services to mutual organisations, particularly in the international transport and professional indemnity sectors, where today they manage a large percentage of the foremost insurance mutuals.



CINS is a shipping line initiative, launched in September 2011, to increase safety in the supply chain, reduce the number of cargo incidents on-board ships and on land, and highlight the risks caused by certain cargoes and/or packing failures. Incidents at sea and during road or rail transport in relation to coiled materials packed in general purpose containers have motivated the shipping line members to collaborate in the production of this guidance document.

Further information, and additional copies can be obtained from the TT Club's Regional Centres:

London

90 Fenchurch Street
London
EC3M 4ST
United Kingdom
T +44 (0)20 7283 4646
F +44 (0)20 7549 4243

New Jersey

Harborside Financial Center
Plaza Five, Suite 2710
Jersey City
NJ 07311
USA
T +1 201 557 7300
F +1 201 946 0167

Hong Kong

1201-1204 Sino Plaza
255-257 Gloucester Road
Causeway Bay
Hong Kong
T +852 2832 9301
F +852 2574 9954

Sydney

Suite 1001, Level 10
117 York Street
Sydney
NSW
2000
Australia
T +61 (0) 2 8262 5800
F +61 (0) 2 8262 5858

Singapore

61 Robinson Road
#11-01A Robinson Centre
Singapore 068893
T +65 6323 6577
F +65 6323 6277

TT Club Network

Antwerp

T +32 3 206 9250
F +32 3 206 9259

Auckland

T +64 9 303 1900
F +64 9 308 9204

Barcelona

T +34 93 268 0555
F +34 93 268 9978

Buenos Aires

T +54 11 4311 3407/09
F +54 11 4314 1485

Dubai

T +971 488 101 67
F +971 488 109 55

Durban

T +27 31 368 5050
F +27 31 332 4455

Genoa

T +39 010 83 33301
F +39 010 83 17006

Hamburg

T +49 40 36 98 180
F +49 40 36 98 1819

Manila

T +63 2 810 1791
F +63 2 817 1740

Moscow

T +7 495 215 2195
F +7 495 215 2196

Mumbai

T +91 212 6129 6800
F +91 212 2284 2356

San Francisco

T +1 415 956 6537
F +1 415 956 0685

Seoul

T +82 2776 4319
F +82 2771 7150

Shanghai

T +86 21 6321 7001
F +86 21 6321 0206

Taipei

T +866 2 2736 2986
F +866 2 2736 2976

Tokyo

T +81 3 5442 5001
F +81 3 5442 5002

CINS – Cargo Incident Notification System

Suite 3, Charter House,
26 Claremont Road
Surbiton
KT6 4QU 2832 9301
T +44 (0)20 8390 0000
www.cinsnet.com